

# AEROLYTE<sup>®</sup> Systems

By Clemco Industries Corp.

## Bicarbonator Soda Blast Cabinet



**Degrease  
Clean  
Strip Paint**

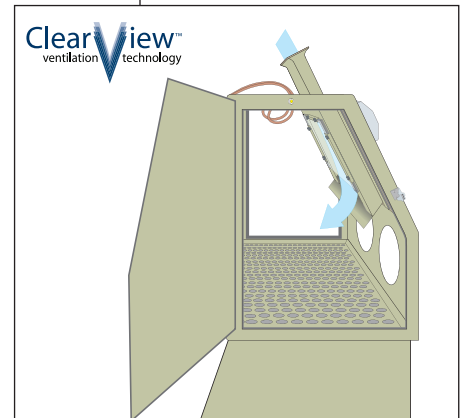

The Aerolyte Bicarbonator Pressure Blast Cabinet is designed specifically for use with sodium bicarbonate media for degreasing, cleaning, and paint stripping without etching the blasted surface. Soda is non-toxic, non-hazardous, and soft, making it ideal for delicate substrates; and it is water-soluble simplifying the process of residual media removal and disposal.

### The Aerolyte Bicarbonator Cabinet Features

#### **Safety**

- Door interlock system interrupts blasting when either door is opened
- Optional time-delay locking system keeps doors locked for predetermined time
- Double-wall, insulated doors, reduce exterior noise
- Full-opening doors with lift-off hinges maximize work chamber capacity and ease loading large parts
- Full-length, neoprene-on-fabric gloves offer long wear life and operator protection
- Dual 15-watt fluorescent lights illuminate the work chamber and stay cool

#### **Productivity**

- Patented ClearView™ targeted high-velocity ventilation technology provides exceptional visibility
- Performance nozzle, 3/16" orifice, venturi-style, aluminum
- 600 cfm pull-through ventilation - sized to keep pace with 3/16" nozzle - provides outstanding visibility and traps 99.7% of dust down to 0.5 micron
- ASME-code pressure vessel, 0.5 cuft capacity, with 1/2" piping

#### **Convenience**

- Tilt-out window allows tool-free glass changes in minutes
- Easy-to-reach pressure regulator, gauge, and electric switch
- Built-in air gun conveniently located inside allows part blow-off inside cabinet

Unique patented ClearView™ ventilation channels air downward to clear the air of dust and media in the operators view area, providing visibility unlike any other cabinet on the market.

#### **Common Applications**

- Cylinder heads
- Engine parts
- Transmission valve bodies
- Oil pumps
- Gearbox bodies and parts
- Carburetor bodies and parts
- Fiberglass components
- Automotive body parts
- Aircraft parts
- Delicate substrates

# S P E C I F I C A T I O N S

## COMPLETE SYSTEM

Actual space required depends on equipment configurations, and desired work flow. Allow additional work space for operator and maintenance access.

Cabinet and Dust Collector  
48.5" deep  
48" wide  
94" high

10" Blast Machine and Hopper  
22" wide  
42.5" high

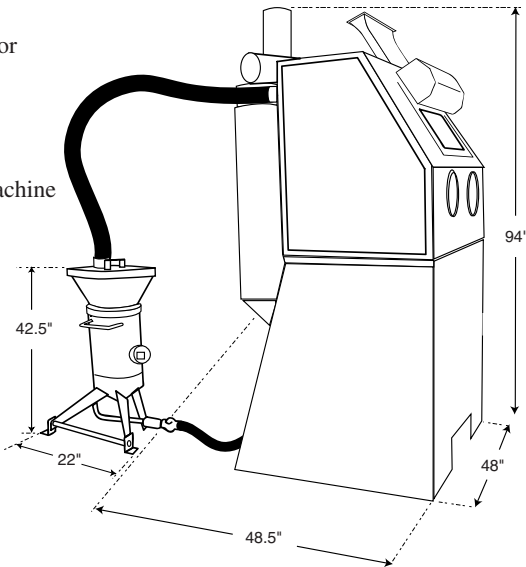

Model Illustrated: PSB 2342B600

## CABINET

### Working Chamber Size

42" wide (1067 mm)  
23" deep (584 mm)  
30" high (762 mm)

### Door Opening

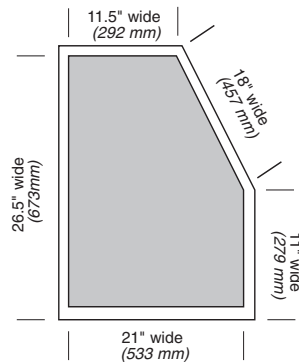

### Window Size (safety glass)

19.5" wide (495 mm)  
12.5" high (317 mm)

## DUST COLLECTOR

The reverse pulse cartridge dust collector traps 99.7% of dust down to 0.5 micron, allowing non-stop, high-production blasting. The polyester-cellulose cartridge is automatically pulse cleaned for maximum filter efficiency. The cartridge can be replaced in minutes.

### Filtering Area

**195 ft<sup>2</sup> (18,1m<sup>2</sup>)**

*Dust concentration in exhausted air is nominally 5.0 mg/m<sup>3</sup>.*

**NOTE:** The Bicarbonator Soda Blast Cabinet incorporates technology covered by US Patent No. 5177911.

The Clemco Industries Corp. Quality Management System is ISO 9001:2008 certified.

## SYSTEM DESCRIPTION

- Model PSB 2342B600 The Bicarbonator
- ClearView™ patented ventilation technology provides the industry's best work chamber visibility.
- 3/16" long-venturi performance nozzle
- 600cfm Cabinet-mounted reverse-pulse dust collector with 1 HP motor
- Filter area: 107 square feet
- Dust drum, removable for easy material disposal
- Heavy-duty 14-gauge cabinet shell, all-welded construction
- Safety-glass view window, 12" x 19.5"
- Fluorescent lighting with dual 15-watt bulbs
- Heavy-duty industrial-quality adjustable chrome latches
- Unique air-logic system to maximize efficient use of compressed air and provide optimal work chamber visibility
- 50 lb capacity (0.5 cu.ft) ASME-code pressure vessel.

## POPULAR ACCESSORIES

- Time-delay Door Locks
- Table/work tray w/internal track
- Turntable
- HEPA Filter

## NOZZLES

### AIR CONSUMPTION

SIZE	NOZZLE ORIFICE	CFM at 80 PSI	M <sup>3</sup> /min.at 5,5 BAR
No. 3	3/16"	38	1,08

Cabinet furnished with ASV-3 nozzle, a high-velocity, high-performance venturi nozzle

## ELECTRICAL

1HP, 115V, 1PH, 60HZ

## ORDERING INFORMATION

Model	Reclaim	Dust Collector	Stock No.	Shipping Wt.
Bicarbonator PSB 2342B600	N/A	Reverse Pulse; 195 sq.ft. Filter Area	27049	1000 lbs 455 kgs
ASV-3 nozzle aluminum, venturi-style 3/16" orif, 3/4" thread			27014	< .5 lbs < .2 kgs

Distributed By: